

Which Nozzle Check Valve Design Should I Specify?

Allistair Balutto July 2020

Introduction

It is an empirical fact that the best type of Check Valves for surge protection is a Co-Axial design. Of the two Co-Axial Designs, Nozzle Check Valves provides a much better performance which has been outlined in a previous document titled "The Difference between Nozzle and Silent Check Valves" which is available here. 

Nozzle Check Valves, like any other pipeline component if correctly sized for the application, will prevent chatter, reduce headloss and maintenance requirements.

There are two basic Nozzle Check Valve designs namely; a single, Central Shaft - Solid Disc design and an Annular Ring Disc type. These two designs share many of the same characteristics but also differ in some areas. REXUS under its CheckFlo brand, manufactures both designs and can therefore provide a better understanding.

Central Shaft Design

The Central Shaft design has a solid disc, is centrally guided and is seated using a single spring. This design has an illustrious history and has been in use with slight evolutions' in the design since the 1930's.

Originally this design was specifically utilised in severe applications in the Petroleum and Industrial markets. REXUS is among the manufacturers who adapted and developed this design specifically for the Water industry making it affordable without compromise to performance.

Generally, Central Shaft Nozzle Check designs require springs with enough force to push the disc into its seat position. The CheckFlo design minimises the high force requirements with the use of a lightweight disc, correctly sized shafts and bearings to maximise response and sealing capability.

The notable features of the CheckFlo Central Shaft Nozzle Check Valves are:

- **Simplicity** – Only one shaft and one spring with a metal to metal seat, making it maintenance free.
- **Reliability** – performance data can be trusted as it is the most researched, most widely used and reference Nozzle Check design.
- **Cost** – low capital cost relative to performance and materials of construction, The CheckFlo Central Shaft design was developed with the Water industry in mind.
- **Highly customisable** – There are three spring options as standard for different flow conditions. Valves are available in either long or short face to face designs. Further materials of construction can be in ferrous steels to stainless steels in various grades. Bespoke valves can be provided for any application.
- **Wide Size Range** – DN50 to DN1200 as standard. Larger valve upon request. Valves are also available for pressure ratings from PN10 to PN100.
- **Short lead times** – Our manufacturing methodologies allow for the shortest delivery within the industry.

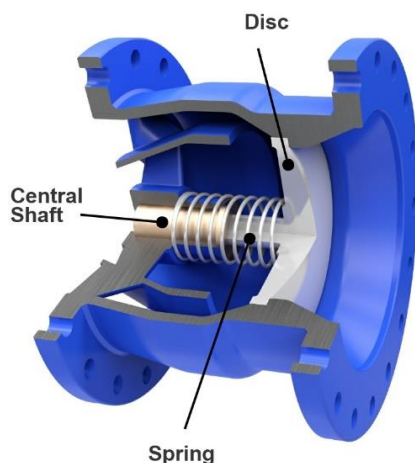

Fig1. Central Shaft Nozzle Check Valve indicating that the design has only one moving part making the design uncomplicated and maintenance free.

Annular Ring Disc Design

The Annular Ring Disc design has a frictionless radial guiding system with multiple springs. Valves of this design also need springs with enough force to push the disc into the correct seat position. The radial guides inherently have larger tolerances implying that the disc may shift off centre and not seal properly when closing slowly.

The notable features of the CheckFlo Annular Ring Disc Nozzle Check Valves are:

- **More Complex** – This design has multiple springs. In addition, the guides have greater tolerances which can result in misalignment under slow closing conditions. Both features increase the potential for maintenance.
- **Limited Size Range** – DN300 to DN1200.
- **Cost** - Higher capital costs when compared to the Central Shaft design.
- **Lead Times** – Longer lead times because of more components and longer assembly times.

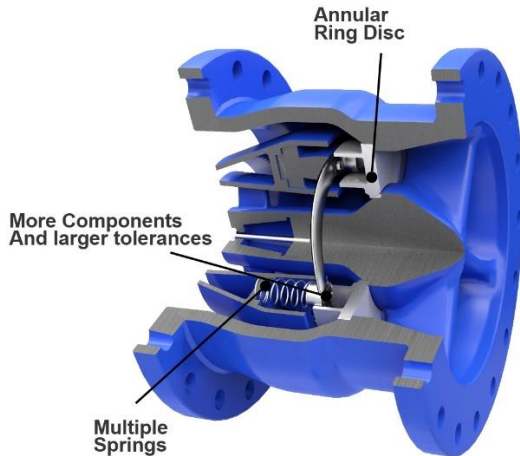





Fig 2. Annular Ring Disc Nozzle Check Valve indicating that the design has more components and multiple springs making it more complex than a Central Shaft Nozzle Check Design

Conclusion

CheckFlo Nozzle Check Valves are available in both Central Shaft and Ring Disc designs. Both designs, correctly sized for the application, will provide good performance. The designs have variations which will impact the choice of either design for a particular application. Of the two designs the Central Shaft design is the most widely used because of its flexibility in its face to face length and pressure rating choices. A summary of the two valves designs are:

Central Shaft Design	Annular Ring Disc Design
Simple design – only on moving part	More complex design – multiple springs
No maintenance	Potential maintenance
Low capital cost	Higher capital cost
Wide size range	Limited size range
Highly customisable	Only standard configuration
Short lead times	Longer lead times

CheckFlo Check Valves are part of a larger range of Pipeline Products from Rexus which includes:

			
AirFlo Variable Orifice Air Valves	CheckFlo Nozzle Check Valves	KII Double Offset Butterfly Valves	KII Mechanical Couplings